



DIM-1 DASH MOUNT NIGHT BRIGHTNESS ADJUSTMENT

In order for the automatic dimming feature of the display system to operate properly, the “DIM” terminal must be connected to the park light or tail light circuit. The display system will go into dimming mode whenever the “DIM” terminal has 12 volts applied to it. The display intensity for nighttime driving is adjustable.

For STR-B, STR-C, and STR-D systems the brightness adjustment located on the side of the control box, next to the display cable, will control the maximum brightness when the headlights are turned on. With the display system on and the headlights on, turn the brightness adjustment to the desired maximum brightness. Clockwise increases the display intensity. If the adjustment is full clockwise (this is less than one full turn) then the display can be at full brightness when the headlights are on.

For VHX, VFD-1, VFD-3, and VFD-3X systems, connecting the DIM-1 will override the preset night brightness and the DIM-1 will have full control of the brightness.

The dash mount dimmer control, DIM-1, will control the brightness from the maximum level down to a low brightness level. This will only control the brightness when the headlights are on. To wire the dimmer, connect the blue w/white wire from the center terminal on the DIM-1 control to the intensity adjustment terminal marked “ADJ”. Connect the black wire from the left terminal on the DIM-1 to “ADJ -” or ground. When the headlights are off, the display is always at full intensity.

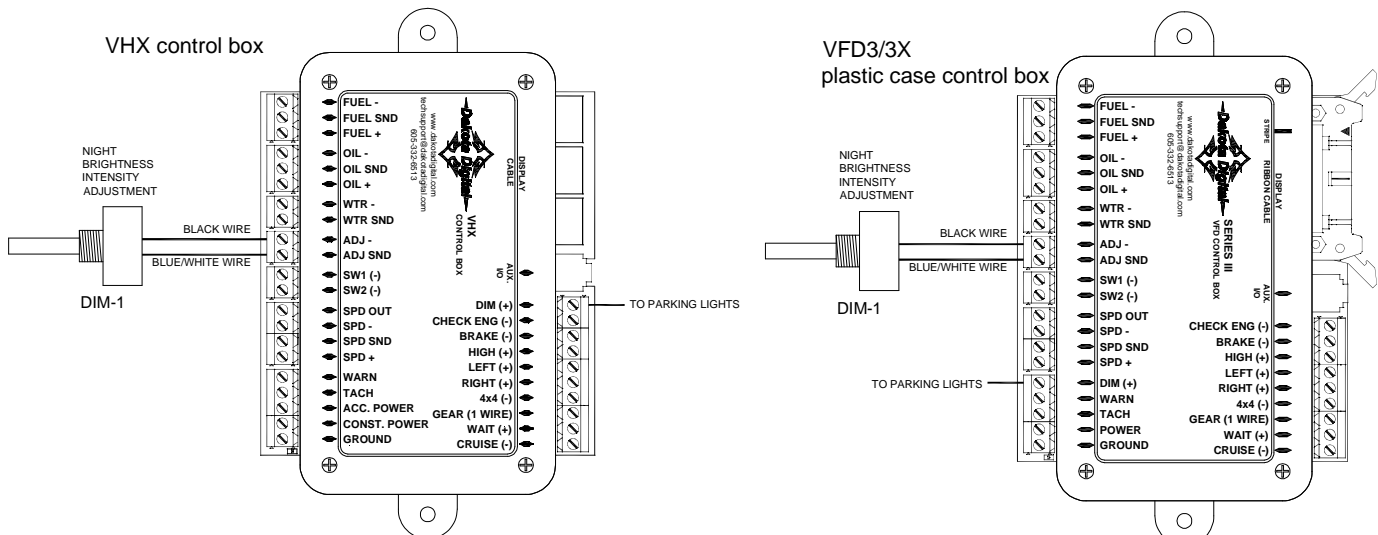

VFD-3 and VFD-3X control box

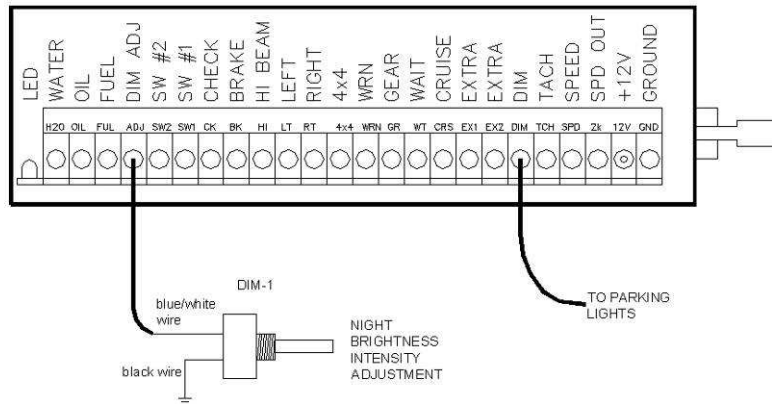

STR3D, 4D, 5D, and 6D control box

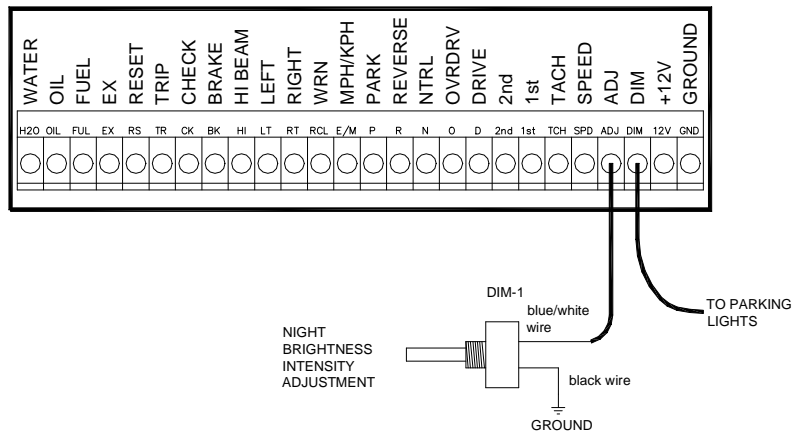

STR3B, 4B, 5B, 6B, 3C, 6C and VFD-1 CONTROL BOX

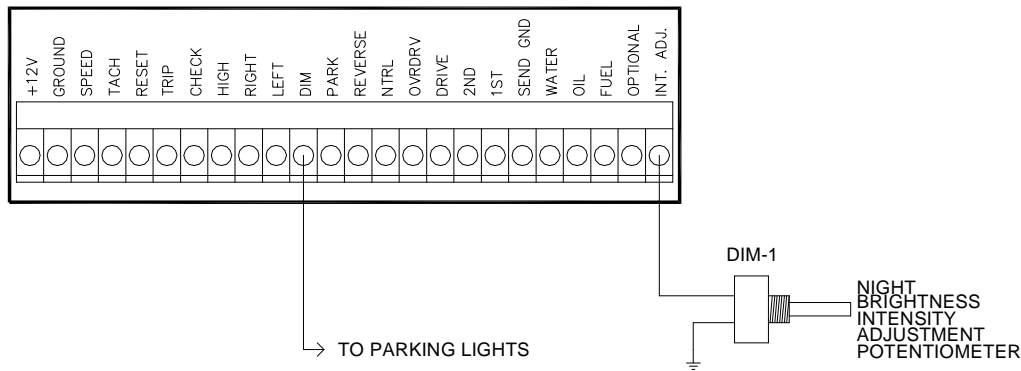

4510 W. 61st St. North
 Sioux Falls, SD 57107
 www.dakotadigital.com
 dakotasupport@dakotadigital.com

Phone (605) 332-6513
 Fax (605) 339-4106

Copyright 2011 - Dakota Digital, Inc.