



# VHX-79F-MUS

Dakota Digital VHX Instrument Installation  
For 1979-'86 Mustang

Your new VHX-79F-MUS kit includes:



## Installation

1. First you will need to remove the stock gauge cluster. To do so, remove the stock bezel by removing the three (3) Phillips screws on the top edge as indicated in the photo. Retain hardware for reassembly.



- Remove the stock gauge assembly from the dash by removing the four (4) screws and detaching the connector and speedo cable on the back side. Retain hardware for reassembly.



- Slide the connectors and speedo cable back in the dash structure to clear the VHX gauges.

- This system comes with two options for the turn signals. You can either have arrows located in the faceplate of your new VHX display, and/or arrows in your vehicle's stock turn signal locations. To use the new faceplate arrows, follow the wiring instructions for the turn signals found in the main VHX manual.

To optionally use the stock turn signal arrows, do not wire the turn signals to the VHX control box. Instead, use the two provided two-wire harnesses. The harnesses plug directly into connectors on the back side of your new VHX system. Connect the wires from these harnesses to your turn signal circuit and ground as shown below. Doing this will light green LED bulbs, located in the original locations of your dash panel, when turn signals are active. Make sure to check left and right to verify they are wired correctly.

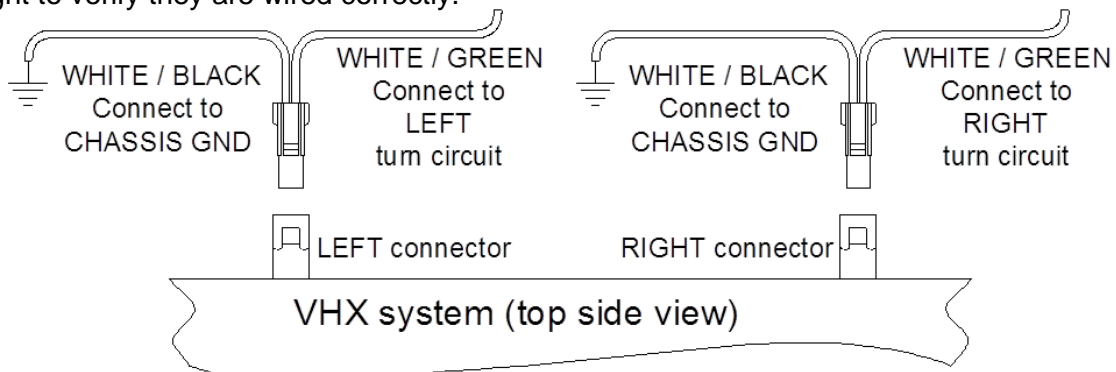

- Attach the provided 36" CAT5 cable and carefully route the other end to the control box mounting location.



5. Position the VHX gauges over the dash and secure the system by using the four (4) stock mounting screws. There is adjustment in the mounting holes so you can assure alignment by placing the bezel over the gauges before final torquing.



- 6A. Both the indicator plate and the warning plate will need to be removed from the back of the bezel to allow clearance for the VHX gauges.



- 6B. Also the small spacer extrusions on the back side of the bezel will need to be snipped off as shown. Depending on being a GT and/or year of the car the number of extrusions and locations may vary. **Any obstruction from the bezel lying flat against the VHX gauges needs to be removed.**



7. Peel the paper off the block-off lens and place it shiny side down over the rectangular openings while making sure all openings are covered. Use silicone to hold the lens in place and avoid handling until the silicone has cured.



8. Reassemble the stock bezel over the VHX gauges using the three (3) stock screws and once again re-assure fit and alignment. Refer to the main manual for wiring instructions to complete the VHX installation.



**⚠WARNING:** This product can expose you to chemicals including lead, which is known to the State of California to cause cancer and birth defects or other reproductive harm. For more information go to [www.P65Warnings.ca.gov](http://www.P65Warnings.ca.gov)



4510 W. 61st St. North  
Sioux Falls, SD 57107  
www.dakotadigital.com  
dakotasupport@dakotadigital.com

Phone (605) 332-6513  
Fax (605) 339-4106

Copyright 2011 - Dakota Digital, Inc.