



ODYR/SLX-20 AMP CURRENT GAUGE

Wiring:

- PWR - connect to fused, switched, 12 volt power (an accessory terminal will work for this)
- DIM - connect to the tail light circuit (when terminal has +12V, gauge will dim)
- SND - connect to the Output terminal from current sensor.
- GND/Gauge case - connect to a main ground location. The sensor and gauge should have a common ground wire to ensure accurate readings.

Earlier style sensors have the following color code: RED – power, GREEN – output, BLACK & WHITE – ground.

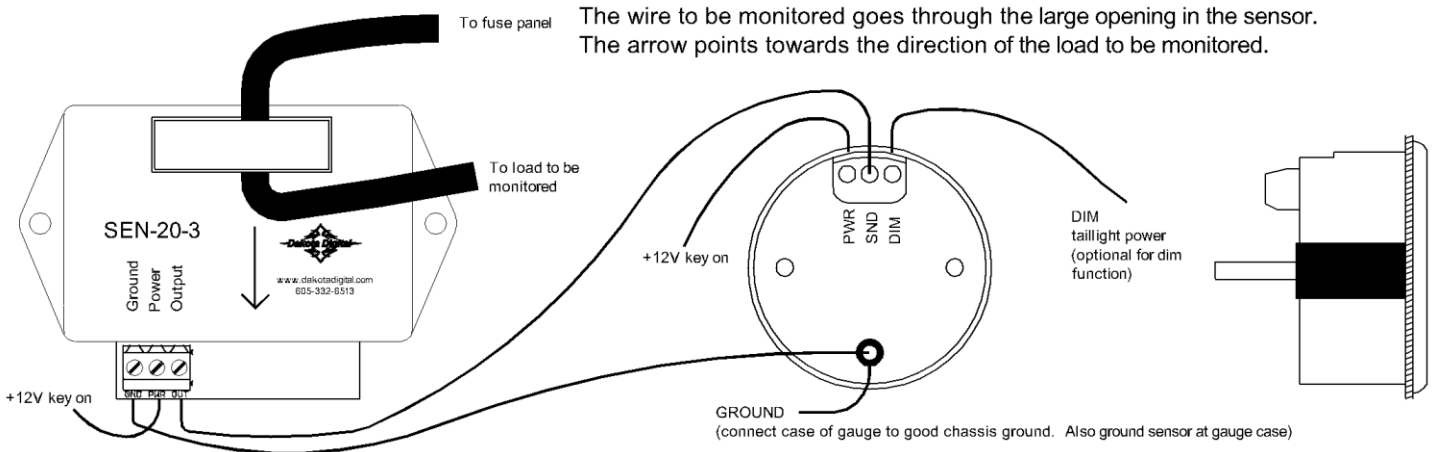

Mounting:

The Series II gauge requires a round hole 2-1/16" in diameter. It should be inserted into the opening from the front and the U-clamp will be installed from the back. Tighten the two nuts on the U-clamp so that the gauge is secure. Gauge depth to the back of the case is 1". Gauge depth including the mounting studs is 1-7/8".

Display update choices:

- FSt (fast) - The display is updated 10 times per second. **(default setting)**
- SLO (average) - The display is averaged over one second.
- HLd (Peak Hold)- The display uses the fast rate and the highest current reading will be held for up to 1/2 second.

- The amp current gauge will operate and read correctly from 3 – 250 Amperes. The sender has an opening which the cable to be monitored must pass through. An arrow on the sensor points towards the end of the power wire leading to the load.
- The sender must be Dakota Digital part SEN-20-3.** Sending units from other manufacturers will cause incorrect readings. The output of the sensor is linear with 0V at 0A, 5V at 250A, and 10V at 500A.

Setting the update speed:

The SND terminal is used to enter and change the warning settings. You will need a wire connected to the SND terminal that can be connected to power while you watch the gauge. The sender must be disconnected from the gauge while this is done. The headlights should be off or the DIM terminal unhooked so that it does not interfere with the setup.

- To enter the set mode, turn the key on with the SND wire powered. The gauge will display "SET".
- Disconnect the SND wire. The gauge will display "SPd". (If you wait too long the gauge will exit the setup routine and you will need to repeat step #1).
- Power the SND wire. The gauge will display the current update speed (SLO, FSt, or HLd).
- Disconnect the SND wire.
- Each time you momentarily power the SND wire the speed setting will change.
- When the desired update speed is displayed, keep the SND wire powered for about 2 seconds. The gauge will display "--".
- Turn the key off.

Troubleshooting guide.

Problem	Possible cause	Solution
Gauge will not light up	PWR terminal does not have power. GND terminal does not have a good ground. Gauge is damaged.	Connect to a location that has power. Connect to a different ground location. Return gauge for service. (see instructions)
Gauge lights up, but always shows zero.	Current is negative. (the wire is going through the sensor backwards) The current being monitored is too small. The sensor is not getting power. The gauge is not connected to the sensor.	Make sure the arrow on the sensor points in the direction to the load. Make sure the wire being monitored is drawing at least 4 amps. Check connection to the sensor power terminal. Check the connection from the OUTPUT terminal to the SND terminal.
Gauge lights up, but does not read correctly.	Loose connection on SND terminal. Poor ground connection. Voltage or wiring problem in vehicle wiring harness.	Reconnect wire. Move ground to different location Check wiring harness for loose or damaged wires.
Gauge lights up, but displays “_”.	SND terminal is shorted to ground. Sender is damaged.	Check wire for damaged insulation. Replace if necessary. Replace sender.
Gauge lights up, but displays “EEE”.	SND terminal is shorted to power. Sender is damaged. Gauge is damaged.	Connect SND terminal on gauge to sender Output terminal. Replace sender. Return gauge for service. (see instructions)
Gauge lights up, but displays “Er3”.	Gauge is not calibrated correctly.	Gauge must be recalibrated. (contact factory)
Gauge lights up, but displays “Er4”.	Gauge setup needs to be reset.	See “Setting the update speed” in the manual
Gauge will not dim.	DIM terminal is not connected correctly.	Check wiring connections.
Gauge remains dim at all times.	DIM terminal is getting power all of the time. Battery is very low. Gauge is damaged.	Connect DIM wire to location that only has power when the headlights are on. Recharge or replace vehicle battery. Return gauge for service. (see instructions)

Technical specifications

Minimum operating voltage	-	7 volts
Maximum operating voltage	-	17 volts
(operating at or near maximum voltage for an extended time can damage unit)		
Maximum current reading	-	250 A
Gauge Resolution	-	1 A
Typical gauge accuracy	-	±3 A
Typical current draw (@ 13.8V)	-	0.1 A

SERVICE AND REPAIR

DAKOTA DIGITAL offers complete service and repair of its product line. In addition, technical consultation is available to help you work through any questions or problems you may be having installing one of our products. Please read through the Troubleshooting Guide. There, you will find the solution to most problems.

Should you ever need to send the unit back for repairs, please call our technical support line, (605) 332-6513, to request a Return Merchandise Authorization number. Package the product in a good quality box along with plenty of packing material. Ship the product by UPS or insured Parcel Post. Be sure to include the RMA number on the package, and include a complete description of the problem with RMA number, your full name and address (street address preferred), and a telephone number where you can be reached during the day. Any returns for warranty work must include a copy of the dated sales receipt from your place of purchase. Send no money. We will bill you after repair.

Dakota Digital 24 Month Warranty

DAKOTA DIGITAL warrants to the ORIGINAL PURCHASER of this product that should it, under normal use and condition, be proven defective in material or workmanship within 24 MONTHS FROM THE DATE OF PURCHASE, such defect(s) will be repaired or replaced at Dakota Digital's option.

This warranty does not cover nor extend to damage to the vehicle's systems, and does not cover removal or reinstallation of the product. This Warranty does not apply to any product or part thereof which in the opinion of the Company has been damaged through alteration, improper installation, mishandling, misuse, neglect, or accident.

This Warranty is in lieu of all other expressed warranties or liabilities. Any implied warranties, including any implied warranty of merchantability, shall be limited to the duration of this written warranty. Any action for breach of any warranty hereunder, including any implied warranty of merchantability, must be brought within a period of 24 months from date of original purchase. No person or representative is authorized to assume, for Dakota Digital, any liability other than expressed herein in connection with the sale of this product.

⚠ WARNING: This product can expose you to chemicals including lead, which is known to the State of California to cause cancer and birth defects or other reproductive harm. For more information go to www.P65Warnings.ca.gov



4510 W. 61st St. North
Sioux Falls, SD 57107
www.dakotadigital.com
dakotasupport@dakotadigital.com

Phone (605) 332-6513
Fax (605) 339-4106

Copyright 2011 - Dakota Digital, Inc.