



Relay Wiring Tips for Dakota Digital's RLY-1 RLY-2 and RLY-3

The purpose of this set of instructions is to explain and demonstrate a few general relay wiring techniques. Relays can be used for numerous vehicle accessories and are not limited to; window motors, door poppers, linear actuators, and solenoids. Relays can also be used to supply power to fuel pumps, lights, fans, and other higher current loads. The purpose of a relay is to switch a high current device with a low current source. This eliminates the need to run large power wires to every switch on the dash.

A relay can switch up to 30 amps to the desired load, 70 amps with the RLY-3. A small coil controls the switching function and draws less than 200 mA, hence a low current switch for a high current load. A typical automotive relay has 5 connections on it, see Figure 1. This is looking at the bottom side of the relay. All of the terminals are numbered and starting at the bottom going around clockwise are: 30, 86, 87, 85 and 87a in the middle. Connections can be made using female spade terminals or the supplied socket with Dakota Digital relays.

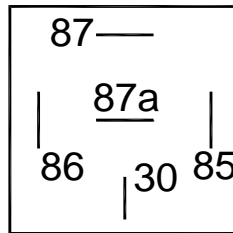

FIGURE 1 Typical Relay Connections

The tables below show the appropriate wire colors for Dakota Digital's RLY-1, RLY-2, and RLY-3 and the corresponding connection number.

RLY-1	
Black	30
Red	86
Green	87
White	85
Blue	87a

RLY-2	
Purple	87(both relays)
Red	86(both relays)
Brown	87a(relay1)
White	87a(relay2)
Blue(large)	30(relay1)
Green(large)	30(relay2)
Blue(small)	85(relay1)
Green(small)	85(relay2)

RLY-3	
Black	30
Red	86
Green	87
White	85

**Note: RLY-3 function is identical to RLY-1 except there is no normally closed contact, 87a, and it can handle up to 70 Amps*

Pin 87 of the relay is the main power or the source for the load to be driven. Most of the time the power wire to pin 87 is a larger gauge wire run direct from the battery with an inline fuse for protection. Pin 30 is the "output" which delivers the power to the load. The wire out of pin 30 is also a larger gauge wire supplying the appropriate amount

of current to the load. Pin 87a is usually not used when supplying +12V to a load, and the terminal is left open, or unconnected.

The relay coil is what is activated to perform the “switching” action. The coil is located between pins 85 and 86. When the relay coil is energized, pins 87 and 30 will be connected. When the coil is off there will be a connection between pins 87a and 30. There are two ways to energize the coil, switching power to the coil or switching ground to the coil.

Most of Dakota Digital's products that require an external relay are ground switching, meaning that the relay control goes to ground when activated. So for these types of outputs one side of the relay coil needs to be connected to +12V power, and the other side to the grounding output of the controller. Figure 2 shows how to connect a single relay pack in this fashion. The relays in Figures 2-7 will supply +12V power to the solenoid, or load, as long as the control output is grounded. This would be a good application for fans, fuel pumps, and other motors.

The green fused +12V power wire should connect direct to the battery to provide a good power source for the desired load. An appropriate gauge wire should also be used for the +12V supply. The black “switched power” wire should also use an appropriate sized wire to supply power to the load. The red and white coil connection of the relay can be smaller gauge wires, around 22 AWG, since there is relatively low current draw.

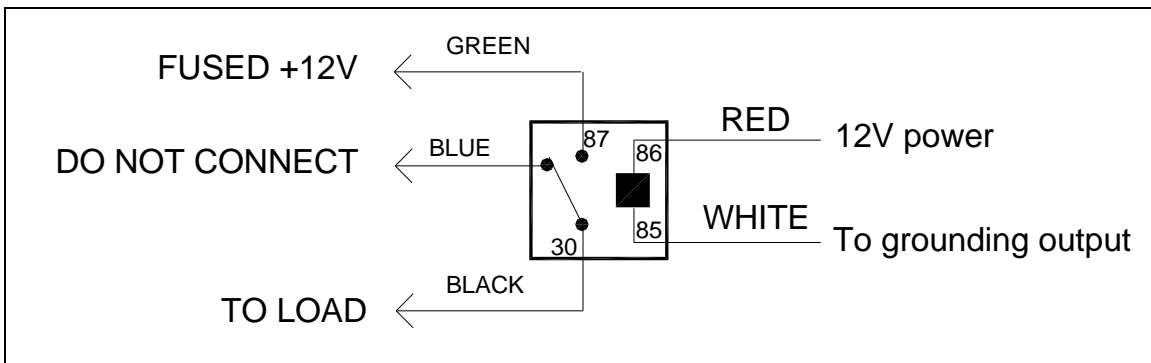

FIGURE 2 Single relay wiring (ground switching relay)

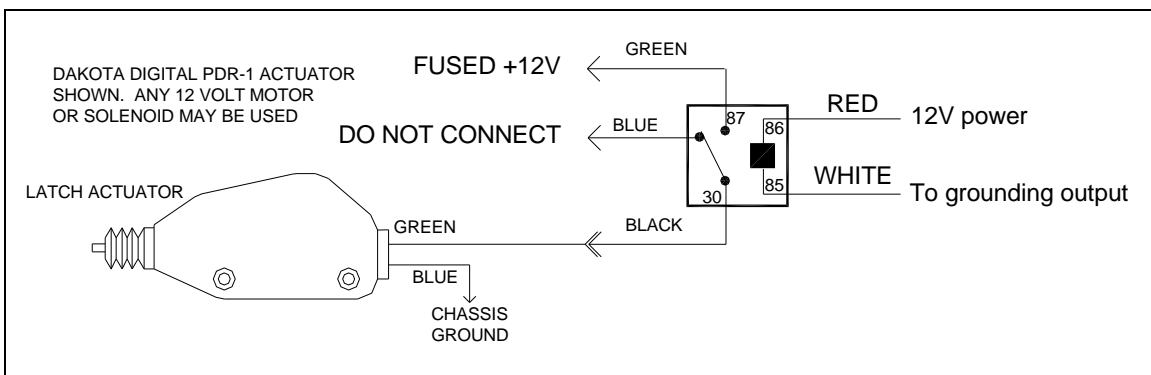

FIGURE 3 Latch wiring (ground switching relay)

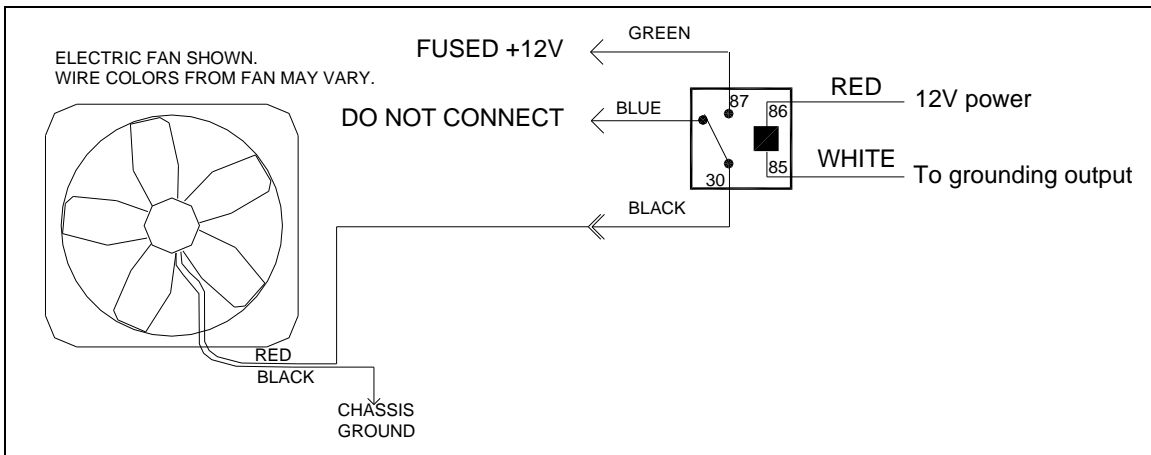

FIGURE 4 Fan wiring (ground switching relay)

The grounding output in Figures 2-4 can also be connected to a toggle or momentary switch, depending on the desired function. For this application, one side of the switch would need to be grounded and the other side would then connect to the white wire of the single relay pack to act as the grounding output.

For power door locks, it is convenient to use a dual relay pack and control the drivers side off of one relay and the passengers side off of the second relay. Ground switching dual relays can be connected as shown in Figure 5 to operate drivers and passenger side solenoids or motors. Again, the grounding output can be a momentary switch with one side connected to ground.

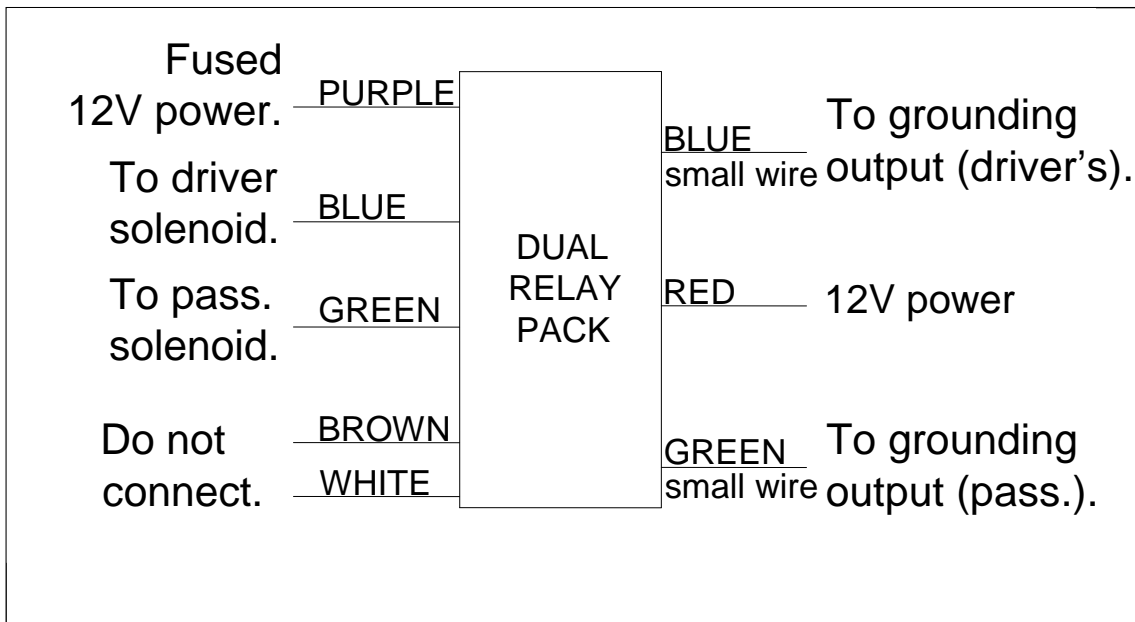

FIGURE 5 Dual (ground switching relay) relay wiring

For power windows, a dual relay pack is also convenient to obtain up and down motion. Figure 6 shows how to connect a dual relay pack to drive a power window motor. The ground-at-rest switch shown supplies 12V to the window motor when pressed so it should have appropriate current ratings if it is being used. The dual relay pack can be used for a power trunk motor connected in the same fashion as the power

window. The dual relay pack will allow for up and down movement of the desired motor or linear actuator.

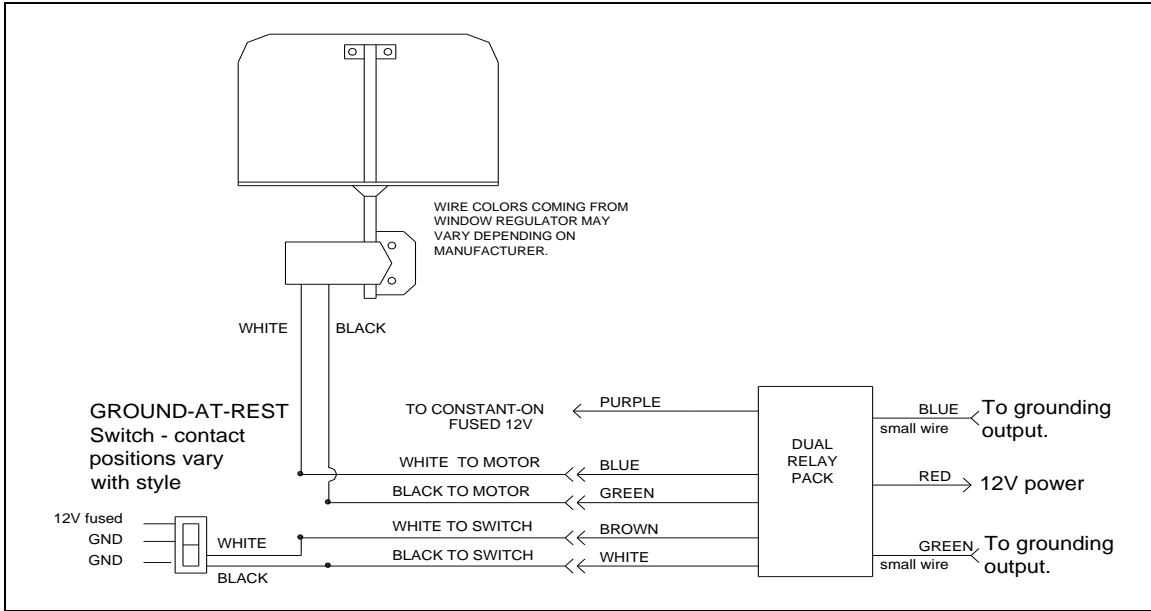

FIGURE 6 Dual (ground switching relay) power window wiring

All of the previously covered wiring connections demonstrate how to ground switch a relay. In some instances +12V switching is desired. The only difference is the ground terminal is now connected to a good ground and +12 V is switched to the relay coil to activate the output.

Figure 7 shows how to connect a single relay and make it +12V activated. The relay will supply +12V to the load as long as +12V is present at the red wire, or the 12V output is activated.

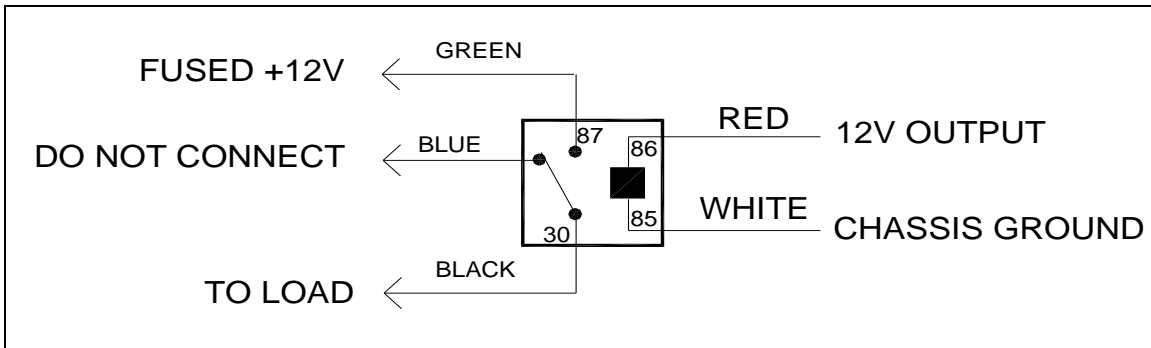

FIGURE 7 Single relay wiring (+12V switched relay)

⚠WARNING: This product can expose you to chemicals including lead, which is known to the State of California to cause cancer and birth defects or other reproductive harm. For more information go to www.P65Warnings.ca.gov



4510 W. 61st St. North
Sioux Falls, SD 57107
www.dakotadigital.com

dakotasupport@dakotadigital.com Copyright 2011 - Dakota Digital, Inc.

Phone (605) 332-6513
Fax (605) 339-4106