

Dakota Digital

CRC-1000

Drive-by-Wire Cruise Control System

Introduction

You have purchased one of the finest cruise control systems on the market. The cruise control features:

Enhanced Adaptability

- Works with GM LS engine/trans drivetrain
- Compact design allows for more mounting locations
- Manual or automatic transmission capability
- Fully plug and play design
- Connects directly to OBD port for less wiring

Enhanced Features

- Compact design
- Removable wiring harness with locking device
- Cruise engaged output (ground signal when engaged)

Easier Installation

- Compact module
- Single unit mounting
- No clutch switch needed
- Plug and play design
- OBD adaptable for less wiring

Improved Operation

- Closer, more accurate control of set speed
- Accurate coast/reduce speed
- Tap-Up, 1 MPH per tap
- Tap-Down, 1 MPH per tap
- Controlled resume rate

Kit Contents/Part numbers

Item	Qty	Description	Part #
1	1	Cruise control module	CRC-1000
2	1	Switch harness	250-XXXX
3	1	Pedal interface harness	250-2766
5	1	OBD DLC Harness	250-2785

Recommended Tools

Safety glasses
Volt-Ohm meter
Soldering iron
Electrical tape or heat shrink



WARNING: DO NOT USE HAND-HELD 2-WAY TRANSCEIVERS INSIDE YOUR VEHICLE WHILE DRIVING.

WHEN TRANSMITTING FROM INSIDE THE CAR, 2-WAY RADIOS THAT OPERATE IN THE 25MHZ-700MHZ FREQUENCY RANGE WITH MORE THAN 2.0 WATTS OF POWER CAN PRODUCE ELEC-TROMAGNETIC INTERFERENCE THAT COULD INTERFERE WITH THE OPERATION OF CRUISE AND THROTTLE CONTROLS RESULTING IN VEHICLE "LIMP-MODE".

USE OF CELLULAR PHONES WILL **NOT** INTERFERE WITH THESE CONTROLS.

DUE TO SENSITIVE NATURE OF SIGNALS USED FOR THIS PRODUCT, ALL NON-PLUG AND PLAY CONNECTIONS MUST BE SOLDERED. FAILURE TO COMPLY WITH THIS REQUIREMENT WILL VOID WARRANTY.



Remove negative battery cable before starting installation process



Connect Data harness cap into OBD2

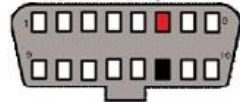

Connect to the accelerator pedal

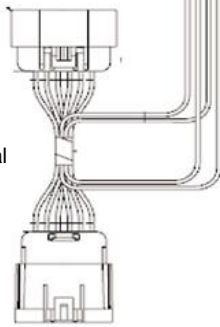

Red wire: Solder to an ignition wire that is +12V only when key on
Black wire: Solder to a chassis ground.

*Optional

*Cut the OBD connector off and solder wires:
Red Wire to Pin 6, Black Wire to Pin 14

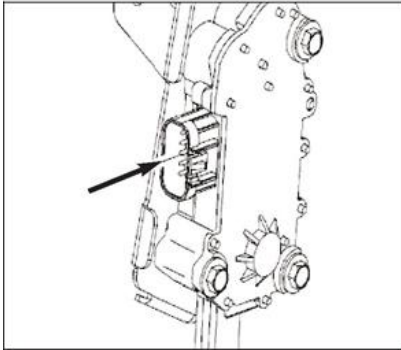
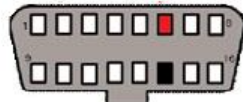

Brake & Indicator connections

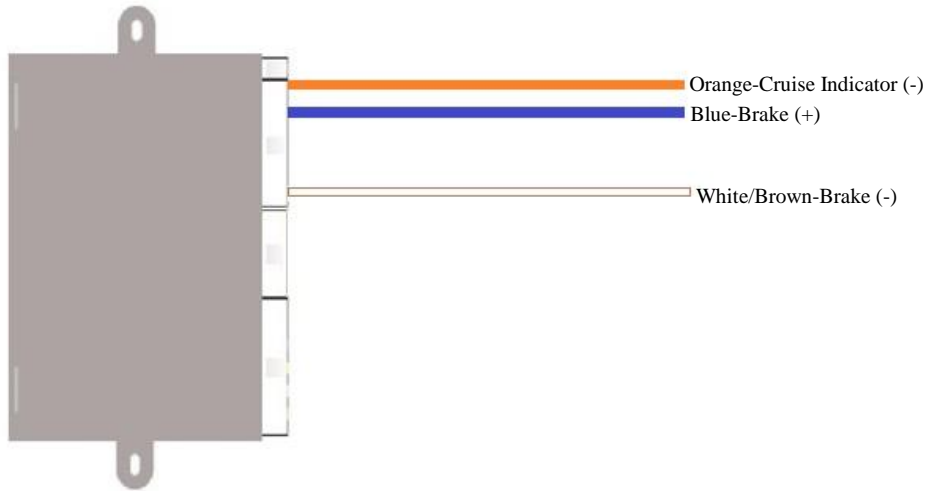

HND (1 and 3) wiring

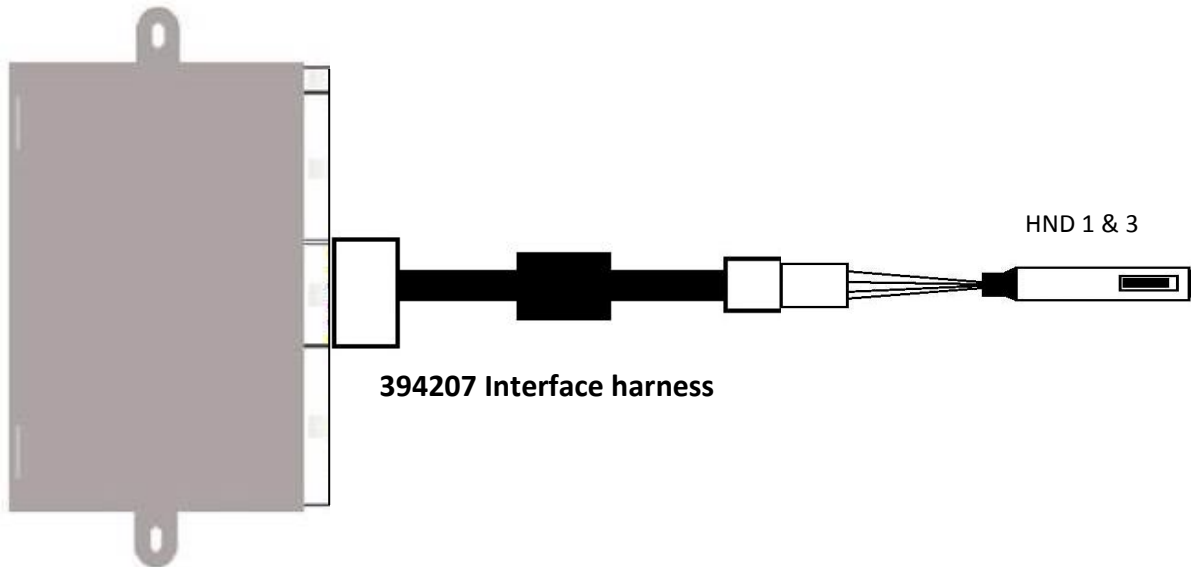

HND 2 wiring

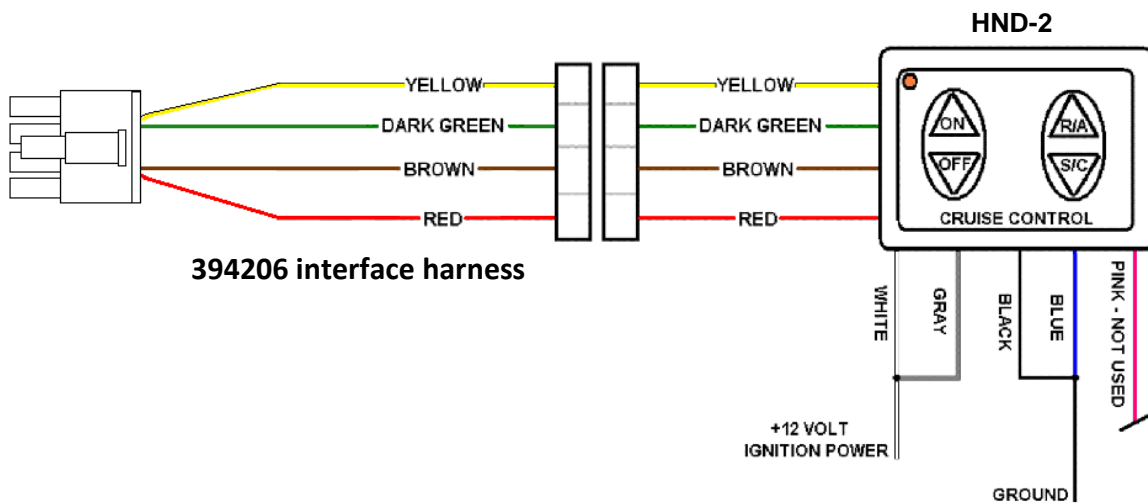

Additional Notes

Wiring Information:

The required wiring connections to the vehicle harness are as follows:

Red: Connect to switched 12 volt source. Ideally, connect to same power location as the engine ECU.

Black: Connect to a good ground point on the chassis or fire wall.

Orange: Connect to cruise (-) terminal on D.D. systems, or you choice of cruise indicators

Blue: Connect to fused terminal that feeds power to the brake lights.

White/Brown: Connect to cold side of brake light switch. This wire should have 12 volts only when the brake is depressed. When the brake is not depressed it should be grounding through the brake light bulbs. If the brake light bulbs are not connected or are burned out, the system will not operate. **LED brake lights will not provide proper grounding.** If you have LED brake lights, use an automotive relay with the white/brown wire between 12 volts and ground as shown below.

Manual transmission vehicles: It is recommended that you connect this kit to a clutch disengagement switch. You may use an OEM switch or the Dakota Digital (SEN-4206). This cruise kit has two dedicated clutch switch inputs: positive triggered and negative triggered. Use a multi-meter to measure the output of your clutch switch and hook the appropriate wire to the clutch switch.

Yellow: Clutch switch (Positive Trigger)

White: Clutch switch (Negative Trigger)

****Note**** If you have LED taillights in your vehicle you will have to run a relay between the brake switch and the cruise control box as shown below. You must use a 5 terminal relay that is normally closed between terminal 30 and 87A.

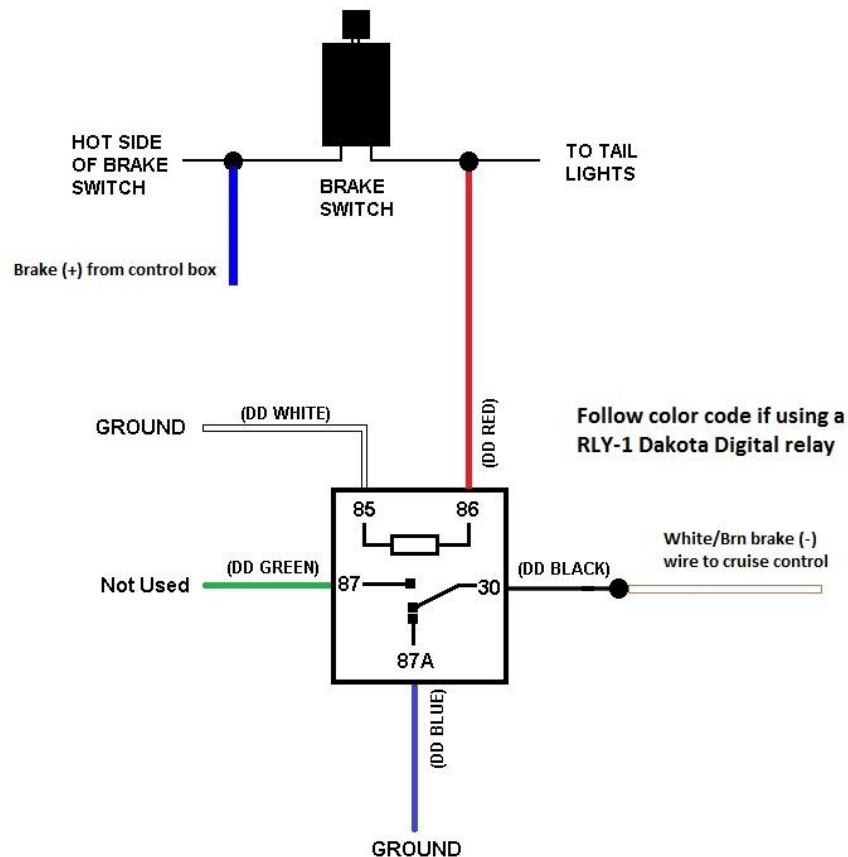

Control switch:

There are various types of turn signal and dash mount control switches that are available. The type of control switch that we supply with the cruise control is a closed circuit type for a turn signal handle control and open circuit for dash mount switches. If you will be connecting to a factory GM four wire control switch, they are open circuit type. GM switches which do not have four wires are not compatible with this cruise control. Ford cruise control switches are neither closed circuit nor open circuit and are not compatible with this cruise control.

Control Box Pin-out

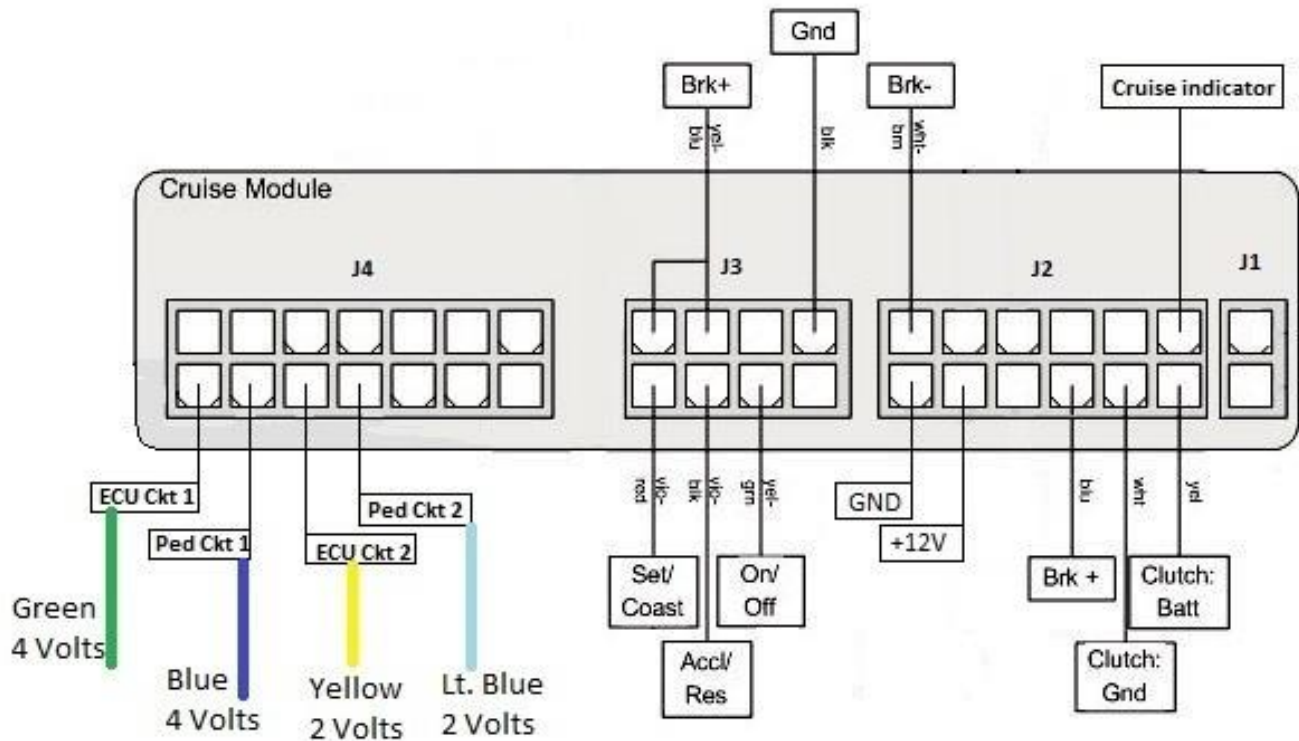

Note: Voltages are with the accelerator pedal fully pressed to the floor. Ensure the key is in the 'on' position and the engine is NOT running.

Troubleshooting guide:

Pin	Color	Desired Results	Fault Condition
J2	Red	+12V when switched on and +0V when switched off. Ignition must be greater than +10V while cranking vehicle.	No power, voltage drop, or intermittent connection will cause loss of pedal or 'Limp-Mode' condition.
J2	Black	Lowest resistance to ground and closest to zero (0) ohms as possible. Use a vehicle ground point where other ground wires are connected to.	A bad ground connection: Cruise will not function, loss of pedal function or 'Limp-Mode' condition.
J3	Vio/Red	Set/Coast: +12V press and hold set.	Cruise will not set if this connection is not installed correctly.
J3	Vio/Blk	Accel/Resume: +12V press and hold resume	Cruise will not resume or accel if this connection is not installed correctly.
J3	Yel/Grn	On/Off: +12V Press On	Cruise will not set if this connection is not installed correctly.
J2	Wht/Brn	Negative side of the brake switch: +0V and 0 ohms to ground when brake is not pressed. +12V when brake is pressed.	Cruise will not function if you don't get desired results. If you get anything but 0 ohms reading you may need to install the brake LED resistor.
J2	Blue	+12V	Cruise will not function if you don't get desired results. Your vehicle may have a faulty brake switch, brake relay or fuse.

SAFETY PROCEDURES

This unit is a microprocessor based Cruise Control. It is designed for ease of installation. Carefully follow the installation procedures in this manual for best results.

DO NOT INSTALL THIS SYSTEM ON A DIESEL POWERED VEHICLE WHICH HAS A MANUAL TRANSMISSION WITHOUT A DISENGAGEMENT SWITCH (Kit# SEN-4206) ON THE CLUTCH PEDAL ASSEMBLY.

WARNING

Failure to follow the instruction manual could not only cause the system to work improperly, but could cause the vehicle to go into 'limp-mode', possibly causing damage to your vehicle and injury and/or death to you and your passengers.

Only install on approved applications. The product described in this manual was developed, manufactured and tested in line with recognized technical standards and is in compliance with the fundamental safety requirements. Nevertheless, there are residual risks! It is therefore important to read this manual before installing and connecting the product. Keep the manual in a place that is readily accessible at all times.

Modifications to the product

The cruise control is designed, manufactured and tested with due regard to safety and reliability. Modifying or tampering with the product can affect its safety. This can lead to death, serious or slight injury to the driver or third parties, or damage to property or the environment. For this reason, the product must not be modified or tampered with!

WARRANTY

The manufacturer warrants to the original retail purchaser of the Dakota Digital Cruise Control that should this product or any part thereof, under normal use and conditions, be proven defective material or workmanship within 36 months or 36,000 miles of the original purchase, such defect(s) will be repaired or replaced (at the manufacturer's option) without charge for the parts.

To obtain repair or replacement within the terms of this Warranty, the product is to be delivered with proof of warranty coverage (e.g. bill of sale), specification of defect(s), transportation prepaid to an approved warranty station.

This warranty does not apply to any product or part thereof which in the opinion of the manufacturer has been damaged through alteration, improper installation, mishandling, misuse, neglect or accident. The warranty also does not cover the costs incurred for removal or reinstallation of the product, or damage to vehicle electrical systems.

This WARRANTY is in lieu of all other express warranties or liabilities. ANY IMPLIED WARRANTIES, INCLUDING ANY IMPLIED WARRANTY OF MERCHANTABILITY, SHALL BE LIMITED TO THE DURATION OF THIS WRITTEN WARRANTY. ANY ACTION FOR BREACH OF ANY WARRANTY HERE UNDER INCLUDING ANY IMPLIED WARRANTY OF MERCHANTABILITY MUST BE BROUGHT WITHIN A PERIOD OF 18 MONTHS FROM THE DATE OF ORIGINAL PURCHASE. IN NO CASE SHALL THE ORIGINAL MANUFACTURE BE LIABLE FOR ANY CONSEQUENTIAL OR INCIDENTAL DAMAGES FOR BREACH OF THIS OR ANY OTHER WARRANTY, EXPRESS OR IMPLIED, WHATSOEVER. No person or representative is authorized to assume for the Company any liability other than expressed herein in connection with the sale of this product.

THE EXTENT OF THE COMPANY'S LIABILITY UNDER THIS WARRANTY IS LIMITED TO THE REPAIR OR REPLACEMENT PROVIDED ABOVE AND, IN NO EVENT, SHALL THE COMPANY'S LIABILITY EXCEED THE PURCHASE PRICE PAID BY THE PURCHASER OF THE PRODUCT.

Some states do not allow limitations on how long an implied warranty lasts or the exclusion or limitation of incidental or consequential damage so the above limitations or exclusions may not apply to you. This warranty gives you specific legal rights and you may also have other rights which vary from state to state.

OPERATING INSTRUCTIONS

NOTE**If the cruise indicator (-) is wired, the indicator may light for up to 10 seconds upon power up. This is normal.

ON: To operate the Cruise Control, turn the power button ON. (Green LED Indicator will light, if equipped.) Wait three (3) seconds before setting speed.

SET SPEED: To engage system, press SET/COAST or press RESUME/ACCEL and release, then remove your foot from the accelerator pedal. Press accelerator and speed will increase, release accelerator and you will return to set speed.

COAST: Press and hold the SET/COAST button and your speed will decrease. Release button and speed of vehicle at time button is released will be new set speed.

ACCEL: Press and hold the RESUME/ACCEL button and your speed will increase. Release button and you will have a new higher set speed.

TAP-UP: You can gradually increase your speed by quickly pressing and releasing the RESUME/ACCEL button. Each time you press and release the button your speed will increase by 1 MPH.

TAP-DOWN: You can gradually decrease your speed by quickly pressing and releasing the SET/COAST button. Each time you press and release the button your speed will decrease by 1 MPH

DISENGAGE: Depress brake pedal slightly; automatic speed control will cease but set speed will stay in the system's memory. Also, you can disengage by pressing button to OFF position, but this erases the memory. To get the RESUME feature to work again, you must first set a speed. Turning OFF the ignition also clears the systems memory.

RESUME: After disengaging system with brake or clutch, press RESUME/ACCEL button and release it. If acceleration rate is faster or slower than you like, drive to within a few MPH of your set speed, then press and release the RESUME/ACCEL button.

About Dakota Digital Cruise Control

The performance of the Cruise Control is dependent upon the condition of the engine, its size and even by the type of emission control equipment it has. Driving at higher altitudes will have an effect on Cruise Control's performance.

Under normal conditions and with proper switch settings, speed should be controlled within plus or minus 1 MPH. There may be situations; however, which make it seem as if the Cruise Control is not capable of functioning accurately, such as an extra heavy load, a very steep hill, or a severe headwind.

CAUTION: Do not use the Cruise Control on a slippery road or in heavy traffic.

CAUTION: (Manual Transmission) While driving with the Cruise Control ON, do not shift to neutral without depressing the clutch pedal, as this may cause engine to over-rev. If this happens, depress the clutch pedal or turn OFF the main Cruise Control Switch immediately.

OUR QUALIFIED EXPERT TECHNICAL SERVICE DEPARTMENT IS READY TO ASSIST YOU WITH ANY QUESTIONS OR PROBLEMS THAT YOU MAY HAVE ABOUT OUR PRODUCT. CONTACT US VIA PHONE AT (800) 852-3228 (USA) OR FAX AT (605) 339-4106 (USA).

⚠ WARNING: This product can expose you to chemicals including lead, which is known to the State of California to cause cancer and birth defects or other reproductive harm. For more information go to www.P65Warnings.ca.gov



4510 W. 61st St. North
Sioux Falls, SD 57107
www.dakotadigital.com
dakotasupport@dakotadigital.com

Phone (605) 332-6513
Fax (605) 339-4106

Copyright 2011 - Dakota Digital, Inc.