



CMD-2000 SERIES REV A REMOTE UP/DOWN DUAL WINDOW CONTROL OR LOCK/UNLOCK CONTROL

INTRODUCTION

Thank you for purchasing the CMD-2000 series Remote Window Control from Dakota Digital, Inc. This, along with many other products that Dakota Digital, Inc. has to offer, represents the latest in electronics technology for the street rod, classic car and truck, and any custom vehicle.

The CMD-2000 Remote Window Control system comes complete with receiver, two key chain transmitters, wiring harness, two dual relay packs, and emergency release switch. An emergency release switch can be concealed on the underside of the vehicle should the door ever be closed with the transmitters inside and you on the outside. Pressing this button will allow reentry to the vehicle.

INSTALLATION

While installation of the CMD-2000 is very straightforward, paying a little attention here and planning out how the system will fit into your specific vehicle will save some time in the long run.

The receiver should be mounted under the dash up on the fire wall for best access to wiring. The kick panel is also another good location for the receiver.

Connect the CMD-2000 system as is shown in the wiring diagram. While the wiring diagram is self explanatory, there are several key areas to pay particular attention to. First, the 12 volt source to the relay packs should be able to supply up to 30 amps. This should have power whether the key is on or off. The CMD-2000 should only be connected to a 12 volt battery for power and never solely to a battery charger. The relay packs will typically be mounted inside the doors to have the fewest wires running through the door jam. The relay packs should be mounted with the wires exiting the bottom to prevent water from collecting inside the sockets.

ADDITIONAL TRANSMITTERS

The transmitters supplied with your remote system are serial number coded for security. Each unit can "learn" up to 4 transmitters. It is also possible to program one transmitter into more than one receiver. If you have more than one vehicle with the CMD-2000 system you can program all of the transmitters into both units. Transmitters from other manufacturers, such as car alarm systems, will not work with the CMD-2000.

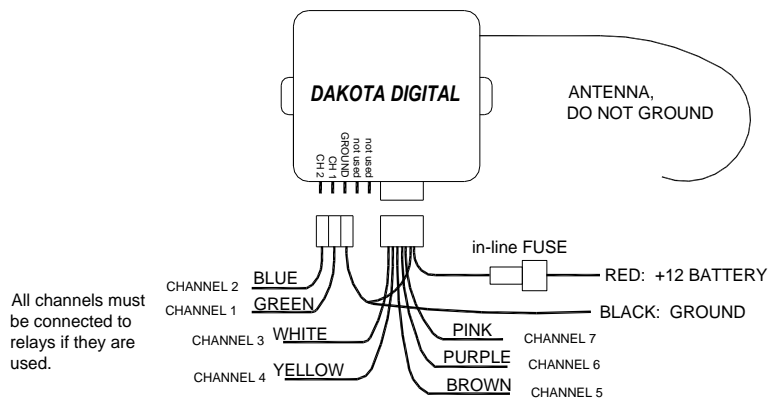

Wiring harness color code.

GREEN	driver's window up relay
RED	constant 12 volt battery source
BLUE	passenger's window up relay
BLACK	chassis ground
WHITE	driver's window down relay
YELLOW	passenger's window down relay
PINK or GRAY	CHANNEL 7 relay (optional)
PURPLE	CHANNEL 6 relay (optional)
BROWN	CHANNEL 5 relay (optional)

The remote system output wires are negative switched outputs designed to turn on external relays. These outputs can only handle 0.25 amps and must be used with a relay. Two dual relay packs are supplied in the kit. To use all 7 channels you will need to purchase three additional relays.

WINDOW CONTROL OPERATION

Each key chain transmitter has four buttons. Each button will activate its own independent channel when pressed. Also, an additional 3 channels can be activated by pressing button 1 and one of the other three buttons at the same time.

- Button 1 activates the driver's window up. The window will continue to move as long as the button is held. Button 3 activates the driver's window down.
- Button 2 activates the passenger's window up. Button 4 activates the passenger's window down.
- Pressing buttons 1 and 2 at the same time can activate an external relay on Channel 5.
- Pressing buttons 1 and 3 at the same time can activate an external relay on Channel 6.
- Pressing buttons 1 and 4 at the same time can activate an external relay on Channel 7.

The emergency release switch can be wired to roll the driver's window down to provide emergency entry to the vehicle.

LOCK/UNLOCK OPERATION

Each key chain transmitter has four buttons. Each button will activate its own independent channel when pressed. Also, an additional 3 channels can be activated by pressing button 1 and one of the other three buttons at the same time.

- Button 1 activates the door actuator to lock the doors. Button 3 activates the door actuator to unlock the doors. The door actuator will remain powered for as long as the button is held. The buttons should not be held more than a couple of seconds to avoid damaging the door lock actuators.
- Pressing button 2 can activate an external relay on Channel 2. This can be used for a trunk latch release or other function.
- Pressing button 4 can activate an external relay on Channel 4.
- Pressing buttons 1 and 2 at the same time can activate an external relay on Channel 5.
- Pressing buttons 1 and 3 at the same time can activate an external relay on Channel 6.
- Pressing buttons 1 and 4 at the same time can activate an external relay on Channel 7.

Two additional wires will need to be passed through each door, along with the other power window wires. This should be done using a flexible rubber tube or rubber grommet to protect the wires, or by using the optional **DAKOTA DIGITAL, INC. MAGNUM SHOOTERS. MAGNUM SHOOTERS** will eliminate the wires running through the door jambs entirely for the cleanest appearance possible. When these highly conductive brass contacts are mounted to the door and to the door jamb they eliminate the wires completely. If you would like to use **MAGNUM SHOOTERS** they can be ordered directly from **DAKOTA DIGITAL, INC.** by calling toll free 1-800-852-3228. Using either the flexible rubber tube, or **MAGNUM SHOOTERS**, route the remaining wires under the dash for the best location and appearance.

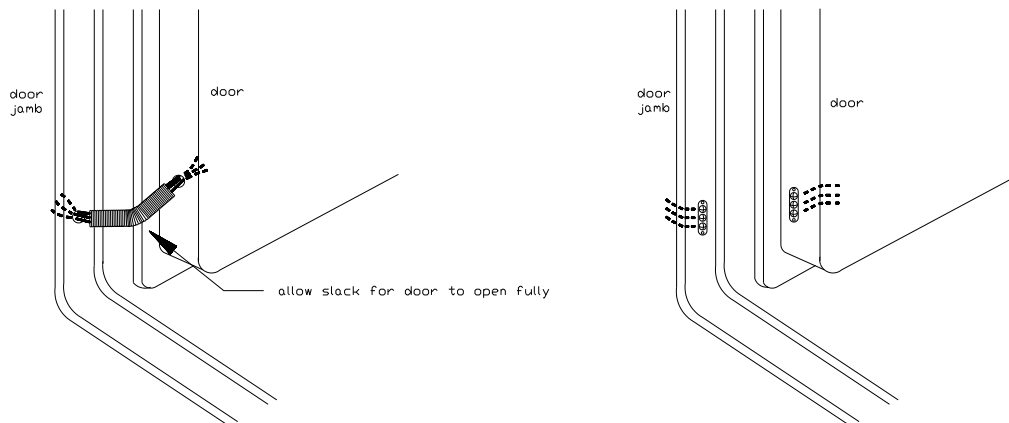

WIRING DIAGRAMS

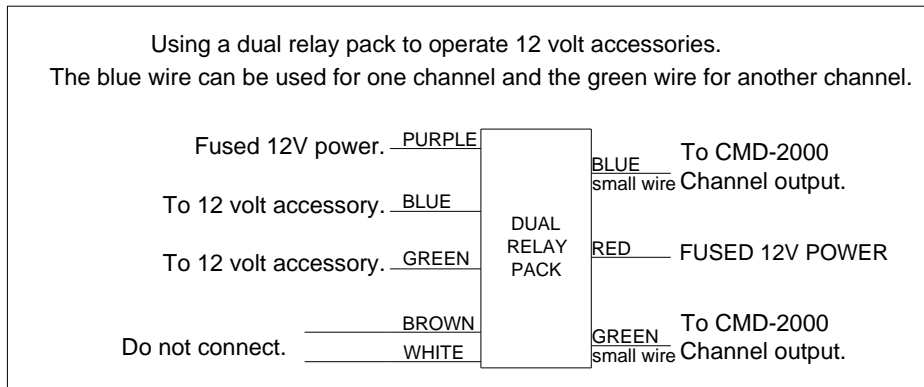
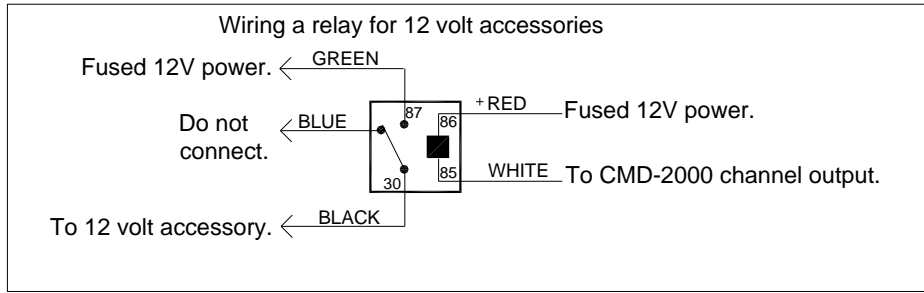

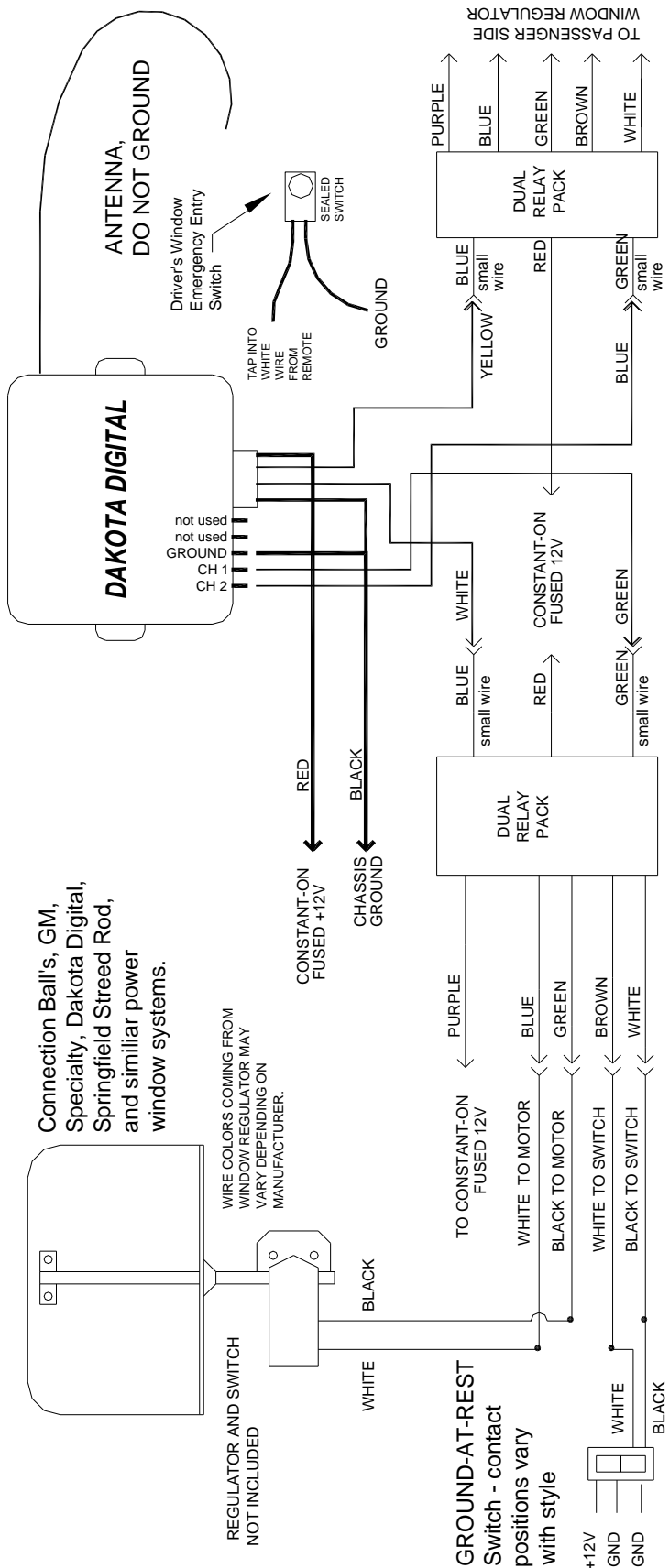

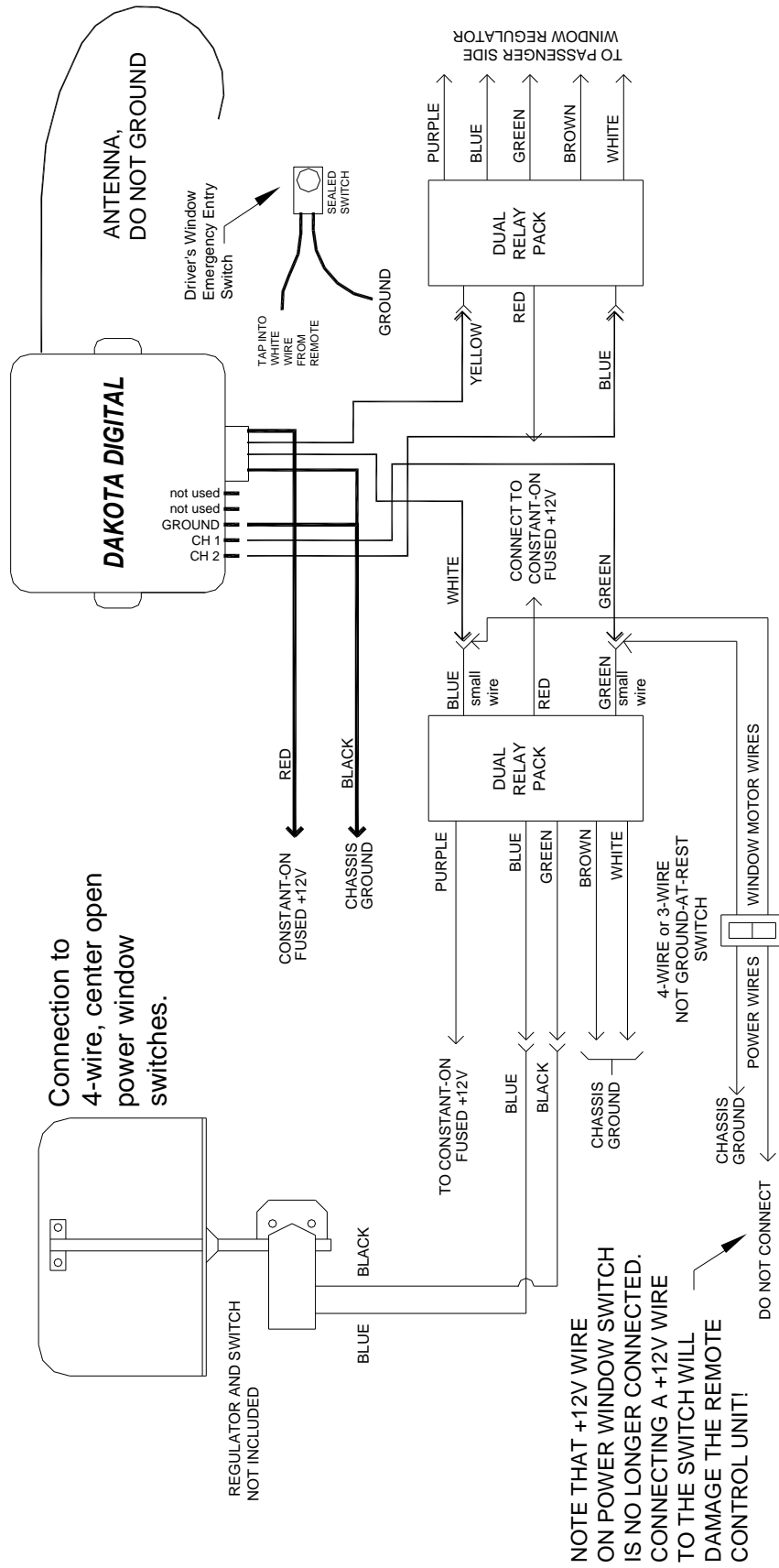

Connection to 4-wire, center open power window switches.

REGULATOR AND SWITCH NOT INCLUDED

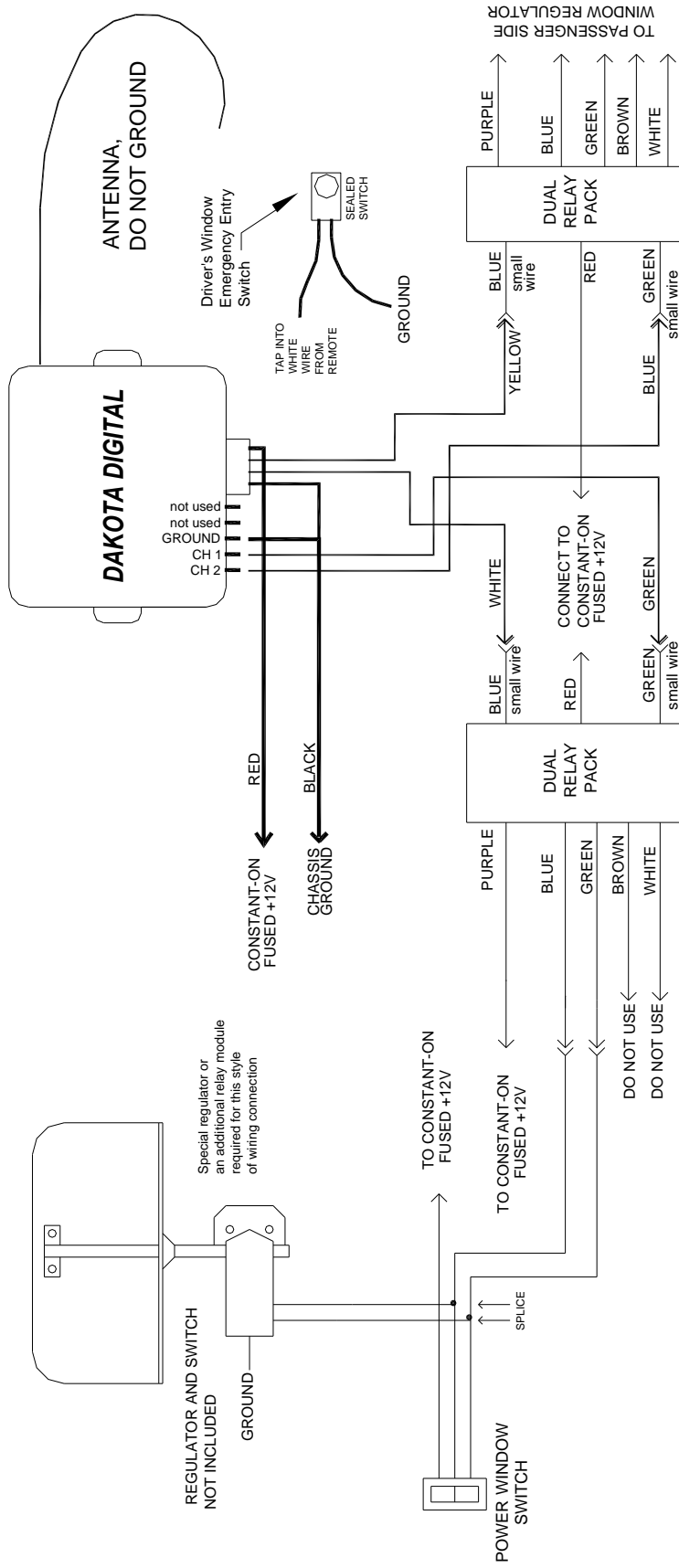

Connection to door lock motors with a 5-wire switch.

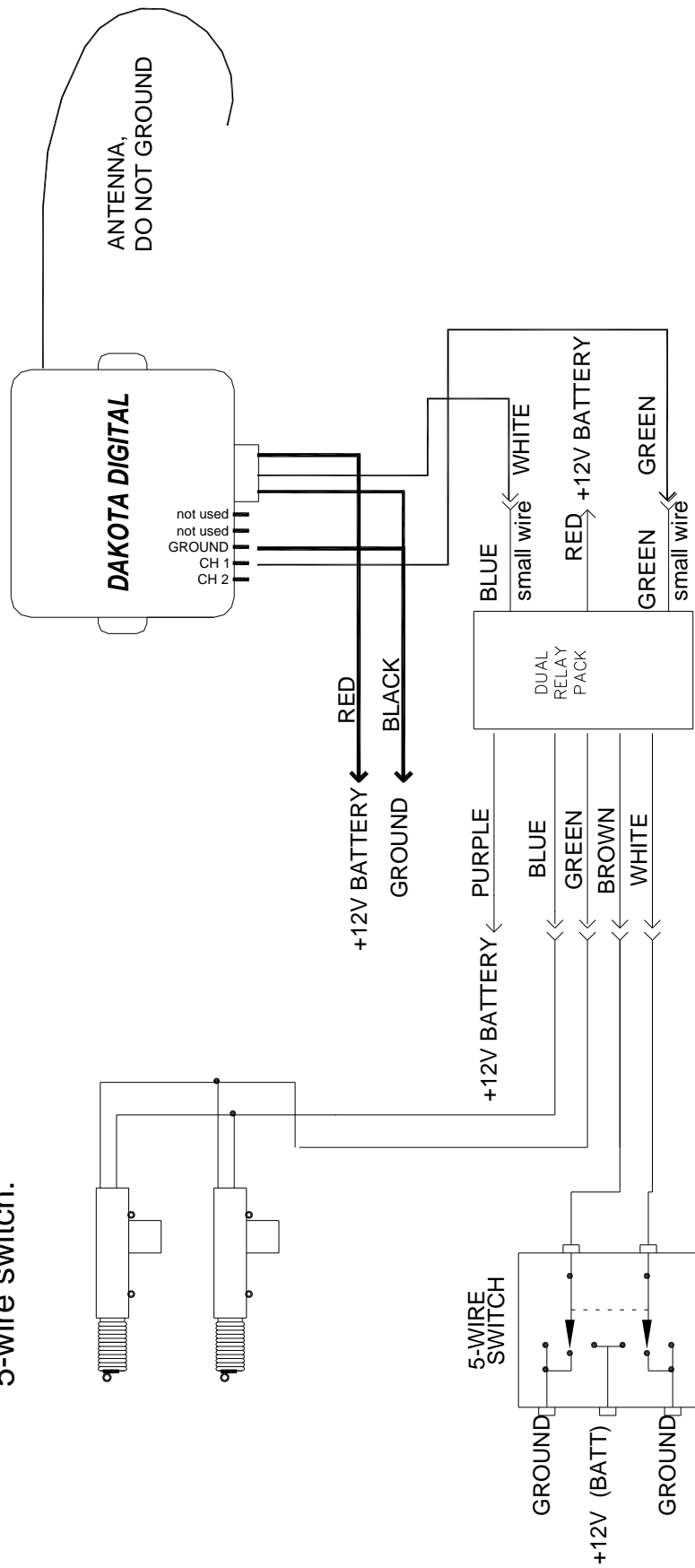

Connection to door lock motors directly without a switch.

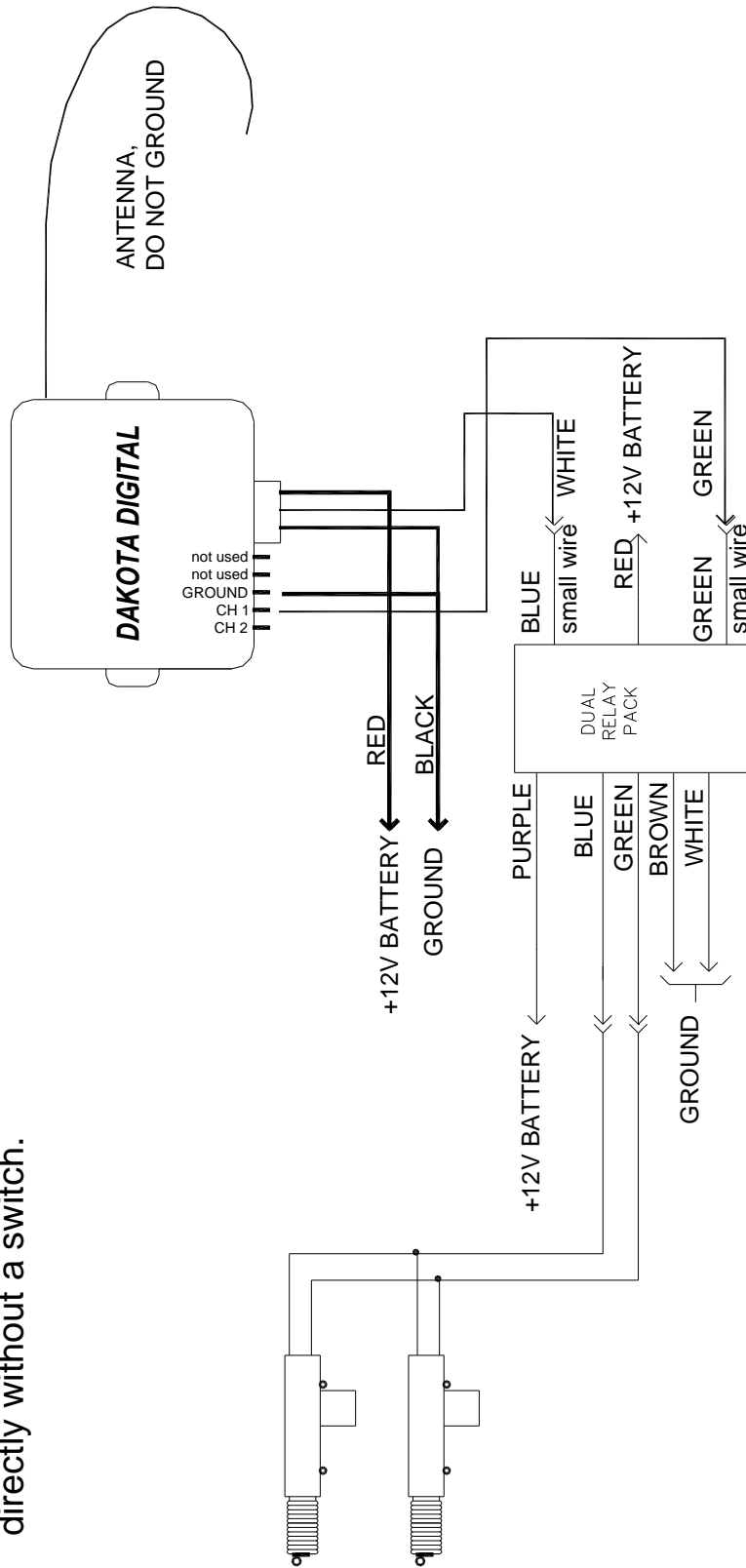

Connection to factory door lock motors with a 3-wire switch.

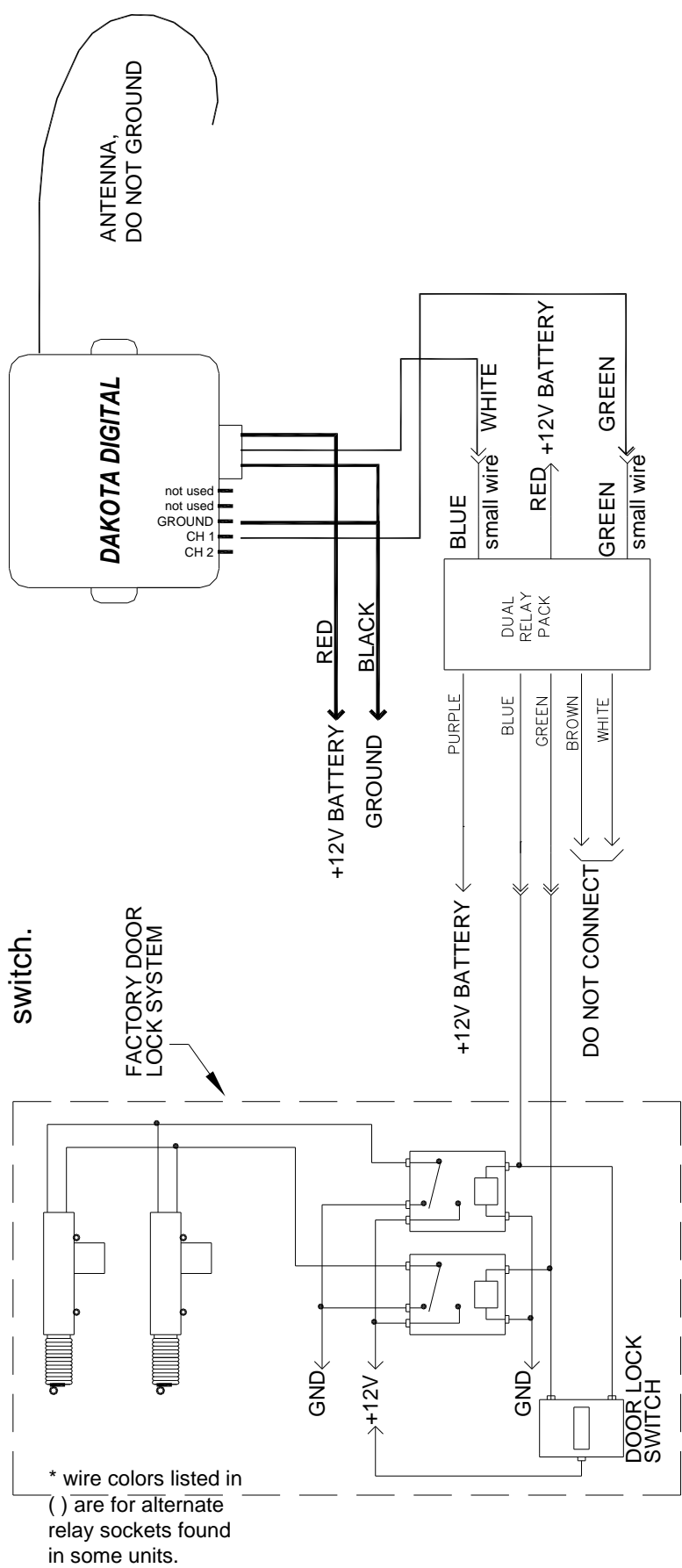

TECHNICAL SUPPORT

If you need any assistance with or have any questions about the wiring or operation of your CMD-2000 remote system, please call the Dakota Digital technical assistance line at (605) 332-6513 or email us at dakotasupport@dakotadigital.com.

TRANSMITTER PROGRAMMING

All of the transmitters to be programmed into the system should be available. This sequence will erase any previously programmed transmitters. If a transmitter is lost or stolen, go through the programming sequence with the remaining transmitters and the lost one will be erased. The programming light (LED) is located on the side opposite the antenna, next to the programming switch.

1. Press and release the programming switch 3 times. The LED should come on and remain on steady.
2. Press button 1 on the first remote. The LED should go out and then come back on steady.
3. Press button 1 on the second remote. The LED should go out and then come back on steady.
4. Repeat this for up to 4 remotes total.
5. When all of the remotes have been programmed in, wait for the LED to go out. The system will now operate normally with all of the remotes.

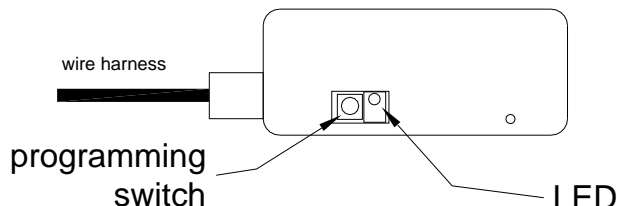

BATTERY REPLACEMENT

Should the transmitter function become weak or erratic, the battery in the key chain transmitter may be weak. An indication of a weak battery is that the red indicator may have a dim glow to it when either button is pressed. If this occurs, first check the system by using the second transmitter provided. If the second transmitter functions properly, replace the battery in the defective transmitter by the following method:

- A. Use a small, flat screw driver or knife to pry the case apart next to the chain.
- B. Carefully separate the two case halves.
- C. Remove the battery noting the (+) and (-) position.
- D. Replace the battery with a new 12 volt type GP23A battery which is available at most electronic stores (Radio Shack, etc.).
- E. Carefully replace the top cover snap it into place.
- F. Check transmitter function.

SERVICE AND REPAIR

DAKOTA DIGITAL offers complete service and repair of its product line. In addition, technical consultation is available to help you work through any questions or problems you may be having installing one of our products. Please read through the Troubleshooting Guide. There, you will find the solution to most problems.

Should you ever need to send the unit back for repairs, please call our technical support line, (605) 332-6513, to request a Return Merchandise Authorization number. Package the product in a good quality box along with plenty of packing material. Ship the product by UPS or insured Parcel Post. Be sure to include the RMA number on the package, and include a complete description of the problem with RMA number, your full name and address (street address preferred), and a telephone number where you can be reached during the day. Any returns for warranty work must include a copy of the dated sales receipt from your place of purchase. Send no money. We will bill you after repair.

Dakota Digital Limited Lifetime Warranty

DAKOTA DIGITAL warrants to the ORIGINAL PURCHASER of this product that should it, under normal use and condition, be proven defective in material or workmanship for the lifetime of the original vehicle it was installed in, such defect(s) will be repaired or replaced at Dakota Digital's option.

This warranty does not cover nor extend to damage to the vehicle's systems, and does not cover diagnosis, removal or reinstallation of the product. This Warranty does not apply to any product or part thereof which in the opinion of the Company has been damaged through alteration, improper installation, mishandling, misuse, neglect, or accident. Dakota Digital assumes no responsibility for loss of time, vehicle use, owner inconvenience nor related expenses. Dakota Digital will cover the return standard freight once the product has been evaluated for warranty consideration, however the incoming transportation is to be covered by the owner.

This Warranty is in lieu of all other expressed warranties or liabilities. Any implied warranties, including any implied warranty of merchantability, shall be limited to the duration of this written warranty. No person or representative is authorized to assume, for Dakota Digital, any liability other than expressed herein in connection with the sale of this product.

⚠ WARNING: This product can expose you to chemicals including lead, which is known to the State of California to cause cancer and birth defects or other reproductive harm. For more information go to www.P65Warnings.ca.gov



4510 W. 61st St. North
Sioux Falls, SD 57107
www.dakotadigital.com

Phone (605) 332-6513
Fax (605) 339-4106

dakotasupport@dakotadigital.com Copyright 2011 - Dakota Digital, Inc.

MAN# 650016:A